

Control Unit – G1 Control Unit (CU021F)

INTRODUCTION

EMUS G1 Control Unit (or simply Control Unit) is the main controller that autonomously executes all core and utility functions of battery management. It interacts with all other first party and third-party components in the system using various inputs, outputs, and interfaces that are populated on its main 22 pin and secondary 8 pin connectors. The device also is flexible and allows by using EMUS Control Panel, to monitor and configure more than 300 battery management system parameters



APPLICATIONS

- Any lithium chemistry, series connected battery pack of up to 100 cells if using serial cell communication. (distributed regular)
- Any lithium chemistry, series connected battery pack, or pack of multiple parallel strings, of up to 3200 cells total, if using EMUS CAN Cell Group Modules. (distributed grouped)
- Any lithium chemistry, series connected battery pack, or multiple parallel string, of up to 512 cells total, if using EMUS Centralized CAN Cell Group Modules. (centralized CCGM)

FEATURES

- USB data interface for quick connection to a host device when configuration, diagnostics, or maintenance is needed.
- RS232 data interface for continuous BMS activity monitoring by using third party or first party EMUS G1 BMS devices.
- Serial interface for cell communication.
- Non isolated CAN 2.0 A/B data interface. Enables to communicate with CAN equipped EMUS G1 BMS components, control third party charging devices
- State of Charge (SOC), State of Health (SOH) calculations.

MECHANICAL INFORMATION

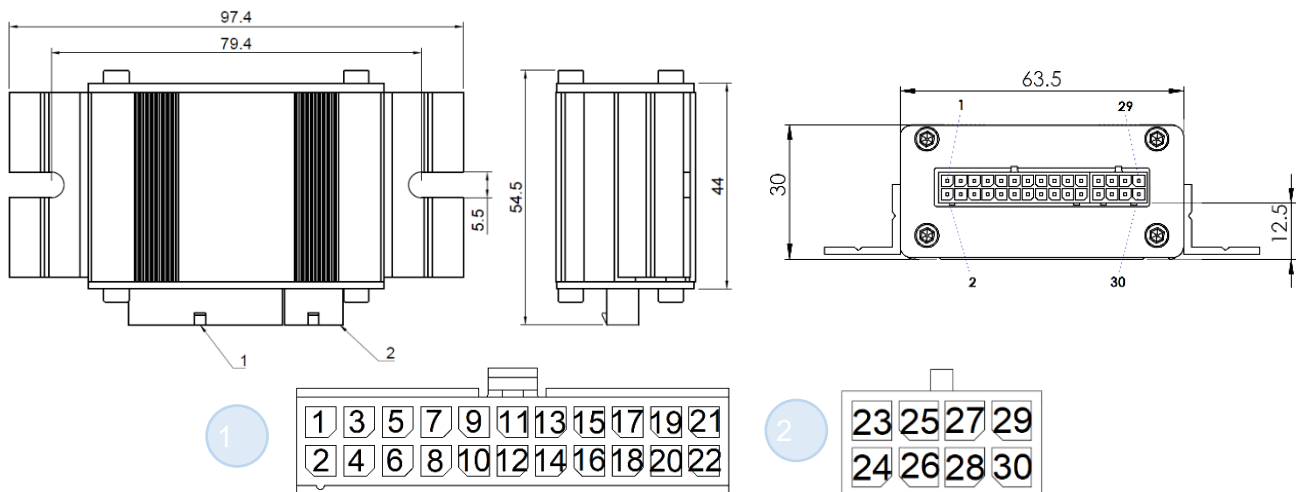



Pin No.	Assignment	Mating Housing	Terminal
1	PWR	43025-2200 Microfit 22 Pin Header or equivalent	43030-0003 (recommended crimp tool Molex Hand Crimp Tool P/N: 638190000)
2	GROUND		
3	CELL RX+		
4	CELL RX-		
5	CELL TX+		
6	CELL TX-		
7	USB PWR		
8	GROUND		
9	USB D+		
10	USB D-		
11	DISP.TX		
12	DISP.RX		
13	HEATER		
14	BAT.LOW		
15	BUZZER		
16	CHG.IND.		
17	CHARGER		
18	FAST CHG.		
19	IGN.IN		
20	AC SENSE		
21	CAN+		
22	CAN-		
23	SPEED IN		
24	SOC OUT		
25	+5V OUT		
26	GROUND		
27	INPUT 4		
28	INPUT 3		
29	INPUT 2		
30	INPUT 1		

ELECTRICAL CHARACTERISTICS

Item	Conditions	Value	
Operating voltage	Nominal	9 to 64 VDC	
	Absolut min/max	7 to 72 VDC	
Power supply reverse polarity protection		Yes	
Current consumption	At typical supply voltage, with nothing else connected	12 VDC typical 26 mA	24 VDC typical 13.6 mA
	At typical supply voltage, with Current Sensor connected (CS013A)	12 VDC typical 39 mA	24 VDC typical 19 mA



Item	Conditions	Value
General purpose output max sinking current (resettable fuse trip current)		0.5 A
General purpose output max voltage		32 VDC
General purpose input ON voltage		5 to 32 VDC
General purpose input OFF voltage		0 VDC
Current sensor input ON voltage	Applies when pin is mapped with function other than PF14 Current	5 VDC
Current sensor input OFF voltage		0 VDC
SOC OUT output voltage range	Sensor Input	0 to 5 VDC
SOC OUT output resistance		1 kOhm
SOC OUT output PWM signal frequency	Applies when pin is mapped with function PF11 State of Charge Output or function PF18 Analog Charger Control Output	7.8125 kHz
SPEED IN input signal frequency range	Applies when SPEED IN input is mapped with function PF1 Speed Sensor Input	7kHz
SPEED IN input ON voltage		5 to 32 VDC
SPEED IN input OFF voltage		0 VDC
USB interface controller		FT232R
USB power supply data line transient/overvoltage protection		5 VDC
USB/RS232 interface galvanic isolation		None
USB interface duplexity		Full duplex (send and receive)
RS232 interface duplexity	USB not connected	Full duplex (send and receive)
	USB connected	Half duplex (send only)
USB/RS232 interface baud rate		57.6kbps
USB/RS232 interface data bits		8 bits
USB/RS232 interface parity		None
USB/RS232 interface stop bits		1 bit

OTHER SPECIFICATIONS

Item	Condition	Value
Max number of Cell Modules in cell communication daisy chain when using Top and Bottom Isolators		80
Max number of CAN Cell Group Modules on CAN bus		24
Max number of Centralized CAN Cell Group Modules on CAN bus		24
Operating temperature		-40 to +85°C
IP rating		IP54
Weight	With quick start kit	181 g
	Without quick start kit	94 g

COMPATIBLE CHARGERS AND INVERTERS

Inverter	Communication Protocol
Afore	CAN
Deye	CAN
Goodwee	CAN
Growatt	CAN
Victron	CAN
SERMATEC	CAN
SMA Sunny Island	CAN
SolArk	CAN
Ateess	CAN
Charger	Communication Protocol
ADY	CAN J1939
Analog Controlled Charger	I/O Controlled
ATIB HTC & HTUD	CAN
Brusa NLG644	CAN
Delta-Q	CANOpen
EDN	CAN
Elcon	CAN J1939
Eltek Valere EV Power	CAN
Enpower	CAN J1939
G-Power EV33	CAN
HF/PFC	CAN J1939
IEB	CAN J1939
Ingeteam	CAN
Micropower Group Lion	CAN
Non-CAN	I/O Controlled
PYLON	CAN
Powerfinn Robust and PAP3200	CAN
Shinry	CAN
Stercom	CAN
TC	CAN J1939
TSM	CAN
Zivan RE protocol	CAN
ZVU	I/O Controlled



NOTE: For all chargers recently supported please refer to <https://emusbms.com>.



NOTE: For more information on each charger communication protocol, contact the charger manufacturer.