

Current Sensor – Closed Loop Type (CS020B)

INTRODUCTION

The Closed Loop type of EMUS G1 Dual Range Current Sensor is a highly accurate hall-effect current measurement device. The rugged, closed-loop design allows the sensor to be mounted directly on a power cable, which makes the installation easier, improves calibration stability, and eliminates the heat generation issue at high currents.



APPLICATIONS

- Specifically designed to be used in EMUS battery management system.

FEATURES

- Two separate measurement channels with different sensitivity, which allows to accurately measure small currents without sacrificing the range of measurable values.
- The nominal current measuring range is ± 800 A, accuracy reaches 0.5%.
- Hall-effect current measurement method which provides the characteristic galvanic isolation between the sensor and the conductive part.

MECHANICAL INFORMATION

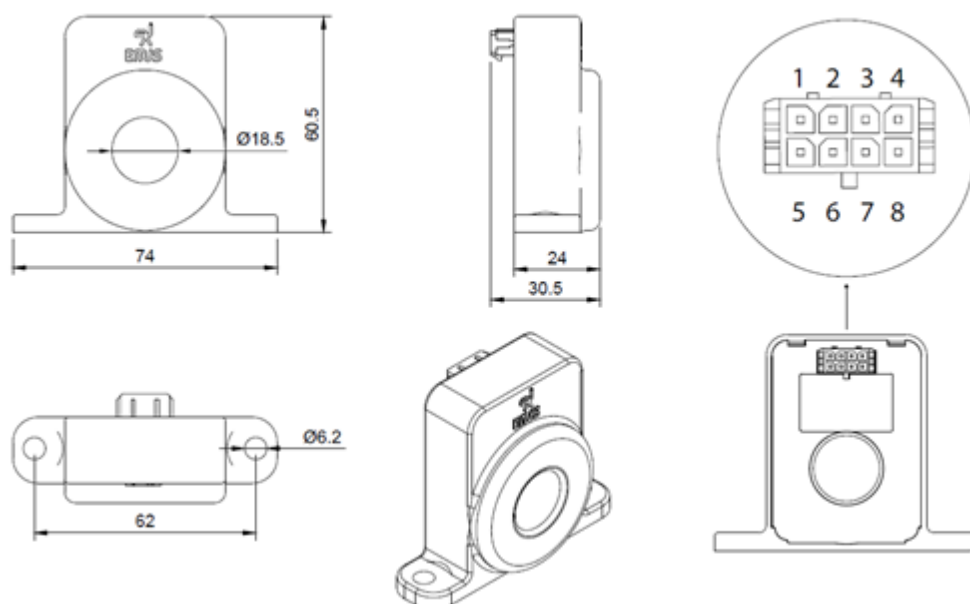



Pin No.	Assignment	Mating Housing	Terminal
1	CHANNEL 1	8 Pin Molex Micro-fit Header 43025-0800	43030-0003 (recommended crimp tool Molex Hand Crimp Tool P/N: 638190000)
2	CHANNEL 3		
3	GND		
4	N.C		
5	CHANNEL 2		
6	N.C		
7	+5V		
8	N.C		

ELECTRICAL CHARACTERISTICS

Item	Conditions	Value
Nominal current measuring range		±800 A
Peak current measuring range	Short bursts with less than 2% duty	±1200 A
Accuracy	When calibrated, at room temperature	0.5 %
Supply voltage		5.0 VDC
Current consumption	At typical supply voltage	19.5 mA
Isolation voltage		>1.0 kV
Conductor resistance		-

OTHER SPECIFICATIONS

Item	Value
Operating temperature	-40to +85°C
IP rating	IP54
Weight	84 g (114 g with cable)
Signal cable length	1.0 m